



**CARINA**

**MACCHINA  
CONFEZIONATRICE  
ORIZZONTALE**

**HORIZONTAL  
WRAPPING  
MACHINE**

**CONFEZIONE**

**CEFFRE**





## FLOW PACK CARINA 500

Confezionatrice orizzontale elettronica per produrre confezioni a cuscino con 3 saldature.

- Caricamento a sinistra ed uscita prodotto a destra
- Struttura in acciaio verniciato grigio RAL 9007 e alluminio anodizzato.
- Carter in acciaio inox AISI 304.
- Piedini di sostegno regolabili in altezza.
- Esecuzione macchina a sbalzo con tutta la meccanica sul retro isolata dal piano di lavoro e protetta dallo sporco e dai residui di prodotto.
- Nastro di alimentazione lungo 2,1 mt.
- Tre gruppi ruote indipendenti per il traino e la saldatura longitudinale del film.
- Tagliacuce rotativo a un settore da 240 mm.
- Motorizzazione degli assi principali mediante tre motori brushless ed un motore AC.
- Porta bobina singolo a sbalzo autocentrante per bobine fino a 500 mm.
- Tappetino di uscita lungo 1000 mm.
- Pannello di comandi con touch screen
- Un tunnel formatore regolabile o un tunnel fisso
- Kit ricambi standard
- Carterizzazioni a norme CEE
- Voltaggio 400 V 3F T+N











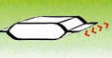

## FLOW-PACK MACHINE CARINA 500

Horizontal Flow Wrapper machine to produce pillow-pack style bags with 3 seals.

- Machine flow direction from left to right.
- Main machine structure in painted steel RAL 9007 and anodized aluminum.
- Guards in stainless steel Aisi 304.
- Support feet adjustable in height.
- Cantee lever style construction in order to fit all mechanical parts separately behind the working packaging area, this concept ensures precision, sturdiness and easy access to all parts.
- Infeed conveyor 2,1 mt. long.
- Three sets of independent fin wheels to pull and seal the film
- One-up transverse rotary sealing jaw (width 240 mm)
- Machine fitted with three brushless motors and one AC motor.
- One cantee lever self-centering film roll holder for 500 mm wide roll complete of standard brake.
- Discharge conveyor belt 1 mt. long.
- Touch screen control panel
- One adjustable or one fixed forming box
- Standard spare part kit complete of tool box
- Machine built according to the EC safety standards
- Voltage 400 V 3 phase N + E

Ulteriori accessori o diversi sistemi di alimentazione possono essere progettati dal nostro ufficio tecnico per soddisfare particolari esigenze.  
Various other customized optional and feeding systems can be evaluated by our technical department.

### CARATTERISTICHE TECNICHE - TECHNICAL FEATURES

									
	120/1'	3900 mm	1100 mm	2100 mm	10 ÷ 220 mm	50 ÷ 600 mm	1 ÷ 120 mm	max 350 mm	500 mm
Machine version	Touch screen	Type of cross sealing unit	Width sealing jaws (mm)	Length infeed	Film width (mm)	Number of fin wheels	Sequence of fin wheels	Feeding of film	
3 brushless motors	✓		240	2.100	500		Cold - Hot - Cold		
Pneumatic opening	Forming box	Outfeed belt (mm)	Wider reel holder	Double up-jaw	Ext. infeed conveyor	Strokes/min	Max height product (mm)	Weight (kg)	
Optional	Fixed or adjustable	1000	Optional	Optional	Optional	120	120	610	

La nostra politica è di continuo miglioramento e sviluppo. Ci riserviamo quindi il diritto di modificare le informazioni contenute in questo depliant senza nessun preavviso.  
Our policy is aimed to a constant improvement and development. We therefore reserve the right to amend the information given in this leaflet without prior notice.

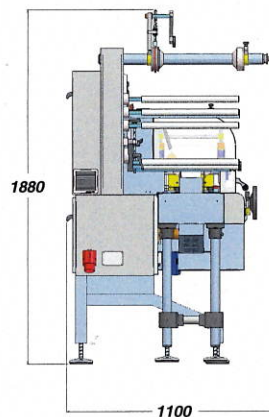
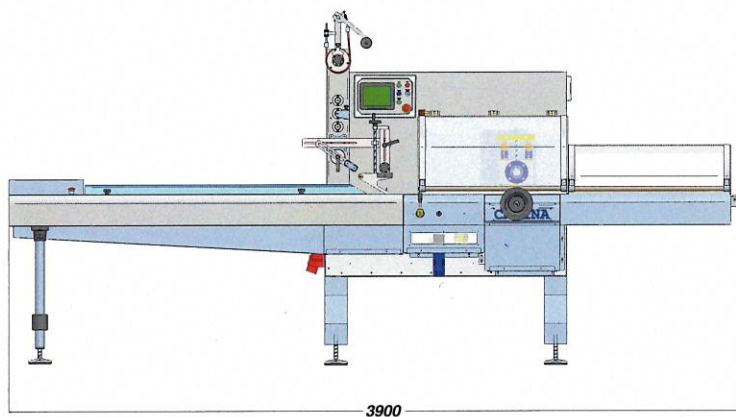
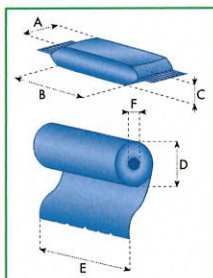
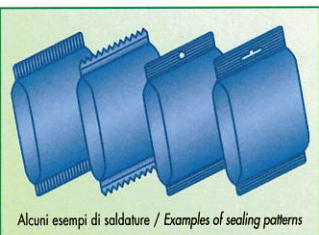

DELFIN s.r.l.  
PACKAGING MACHINERY DIVISION  
Via Keplero, 18 • 36034 Malo (VI) • ITALY  
Tel. ++39 0445 58 06 88 • Fax ++39 0445 58 71 12  
<http://www.delfin.it> • e-mail: [info@delfin.it](mailto:info@delfin.it)